

# Multiphase Pumps & Systems





**Bornemann  
Pumps & Systems**

Worldwide  
Network

## Go With The Leaders

■ Over 10 Years Field Experience In Multiphase Applications



Headquarter  
of Joh. Heinr.  
Bornemann  
GmbH in  
Northern  
Germany.

When the concept of multiphase pumping was first introduced to the market, the specification, packaging, and procurement of this unique technology was initially handled in similar fashion to that of conventional liquid handling pumps.

The heart of the package which is comprised of the multiphase pump, motor, and baseplate were sourced from the manufacturer, valving, piping, and instrumentation was typically sourced by another supplier, while variable speed controls and a PLC may have been sourced by yet another supplier.

Occasionally, this multiple source approach towards packaging led to operation problems due to the fact that one or more of the suppliers were not familiar with the peculiarities of multiphase pumping.

In 1994, Bornemann recognized the need for clients to have a single source supplier responsible for both the hardware as well as the operating process of the equipment in their particular field. Subsequently, Bornemann Multiphase Systems were developed to provide a flange-to-flange solution. Since then, *over thirty (30) Multiphase Systems* have been placed in operation worldwide.

## Multiphase Pumps & Systems

■ Our Commitment To Technological Excellence

### ■ Contents



#### Pumps



<b>Bornemann Multiphase Pump MW Series Technology</b>	<b>2</b>
<b>Bornemann Multiphase Pump MPC Series Technology</b>	<b>4</b>
<b>Bornemann Multiphase Pump Pump Installation Examples</b>	<b>6</b>
Simplicity Of Design, Reliability And User-Friendliness	
■ Superior Pump Technology	
■ Economic Advantages	



#### Systems



<b>Bornemann Multiphase Pump System Technology</b>	<b>8</b>
<b>Bornemann Multiphase Pump System Configuration</b>	<b>12</b>
<b>Bornemann Multiphase Pump System Installation Examples</b>	<b>14</b>
Flange-To-Flange Solutions Tailor-made To Your Specific Application	
■ Onshore Field Installations	
■ Offshore Field Installations	



#### Services



<b>Bornemann Multiphase Pumps &amp; Systems Worldwide Services</b>	<b>16</b>
Complete Program For Our Customers	

→→→ Please take a look at the jacket flap of this brochure for information concerning data.

## Multiphase Pumps MW Series Technology

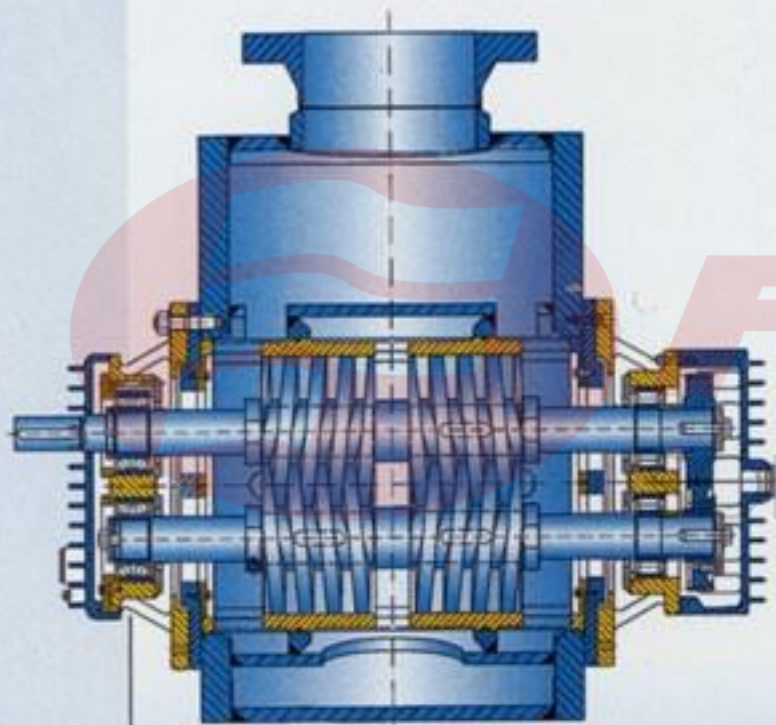

Single-acting mechanical seals with non-pressurized buffer system.

Integrated bypass relief valve.

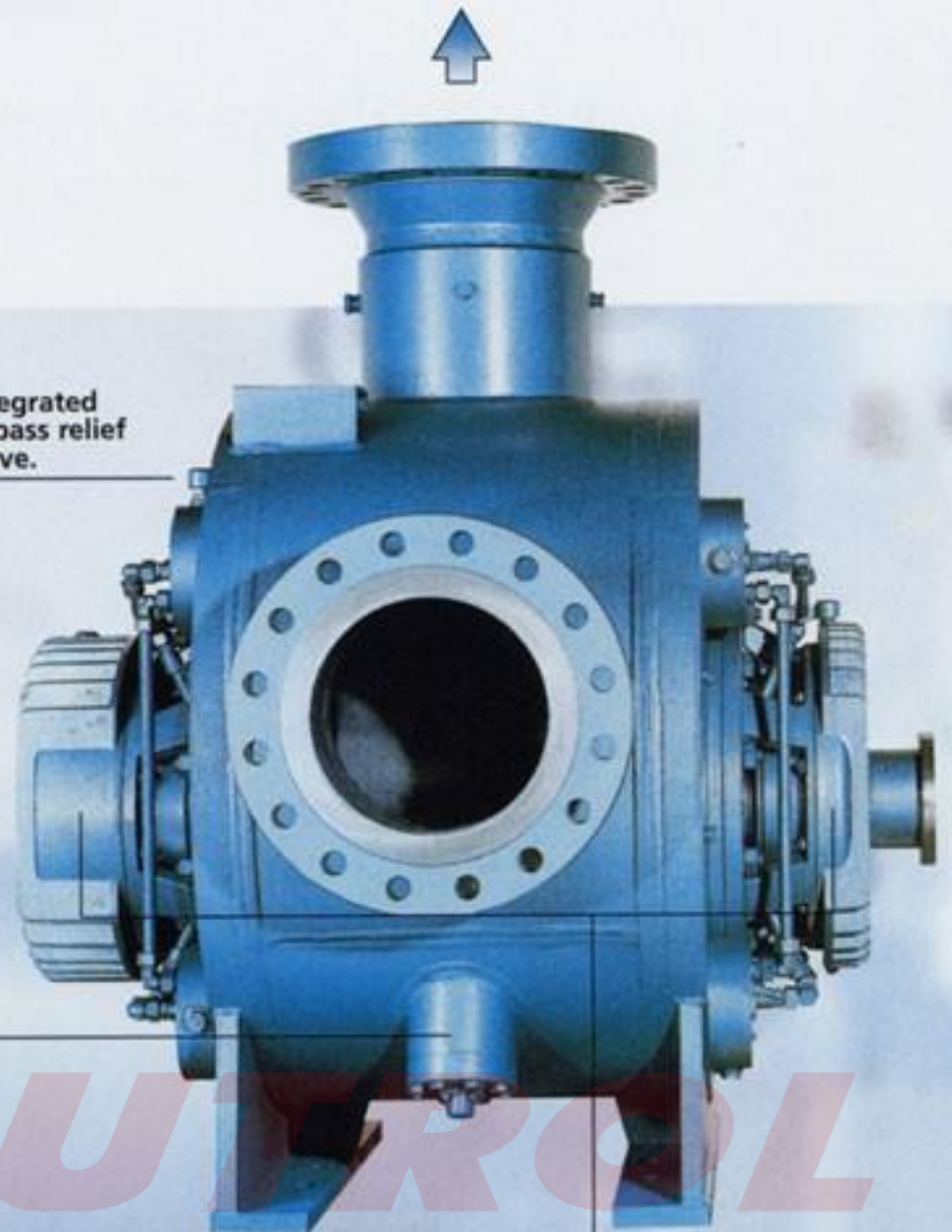

Patented integral circulation system.

Oil-lubricated external bearings and timing gears ensure maximum service life and minimum maintenance requirements even in heavy duty applications.

Single-acting mechanical seals with non-pressurized buffer system, with wear-resistant silicon carbide/carbon seal faces.

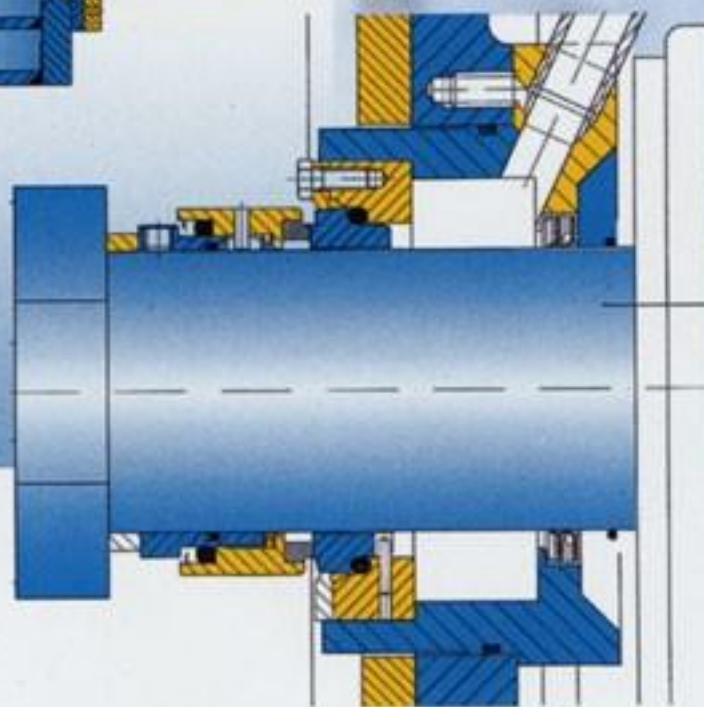

### MW-Series Advantages

- Design for inlet pressures up to 290 psi (20 bar) and differential pressures up to 700 psi (50 bar).
- Capacity up to 280,000 BPD (1,800 m<sup>3</sup>/h).
- Patented integral circulation system.
- No need of external cooling or lubricating systems.

Diff. press. up to 700 psi  
(50 bar)

Bornemann  
Multiphase Pumps  
MW Series Technology –  
Specific To Your Needs

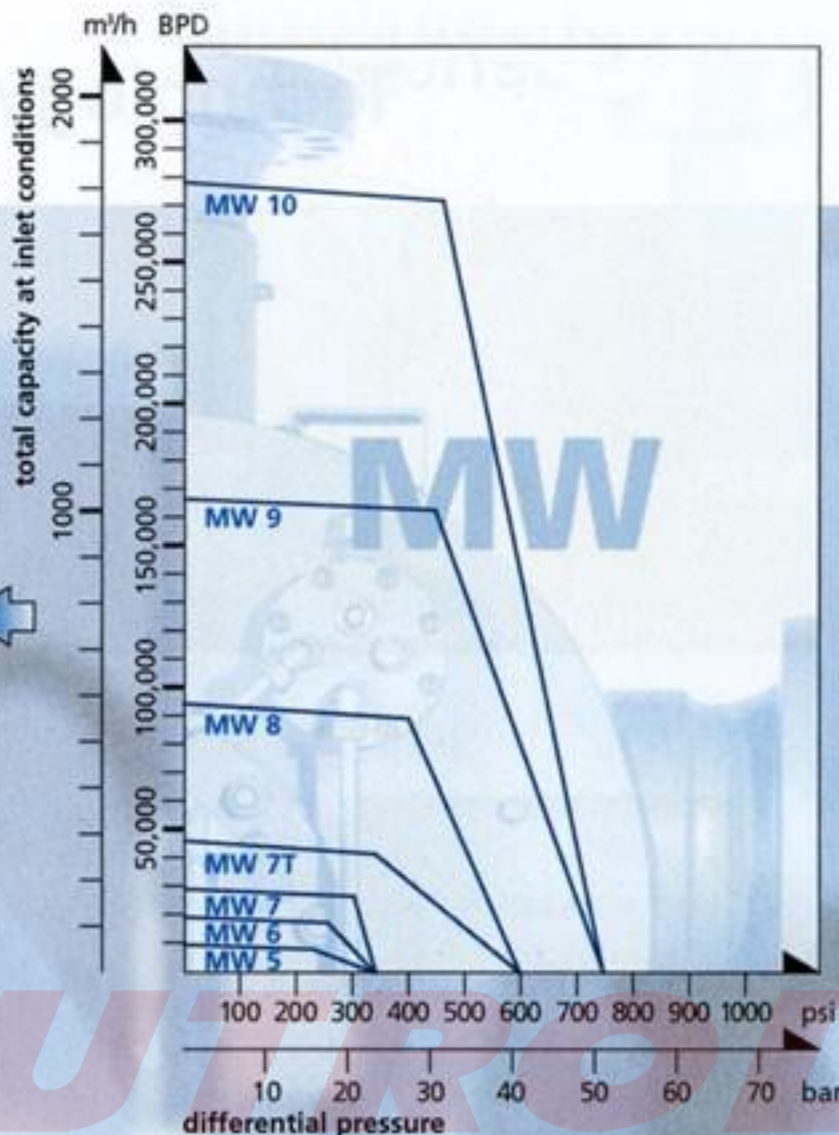
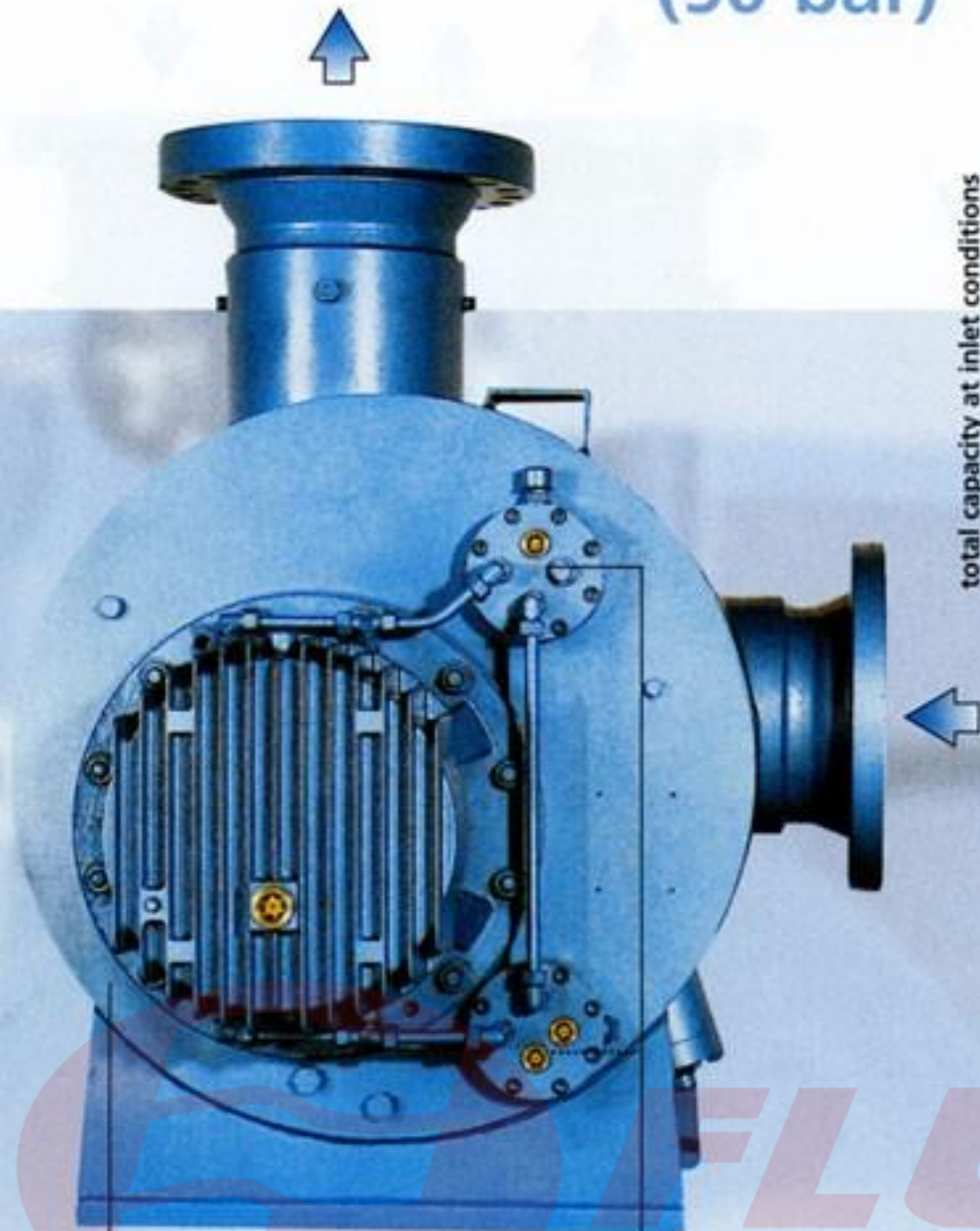

Fully welded pump casing with large separation chamber provides outstanding dry-running capability.

Non-pressurized buffer system.

■ Selection Of Pump Type

Of the many variables which must be considered in selecting a multiphase pump for a given application, inlet pressure is the decisive factor for the most economical model.

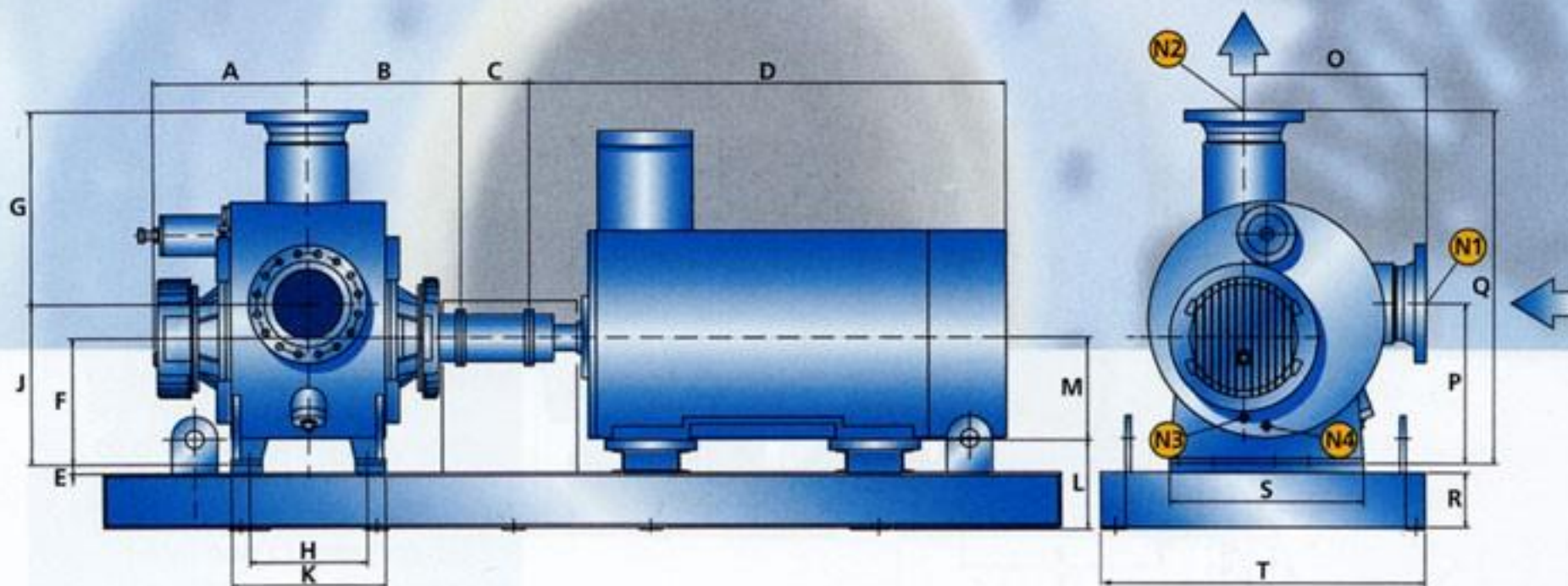

→→→ Please take a look at the jacket flap of this brochure for further information concerning data.

Get In Contact: Phone +49 (0) 5724 390-0 ■ Fax +49 (0) 5724 390-290  
E-mail: info@bornemann.com ■ Internet: www.bornemann.com

## Multiphase Pumps MPC Series Technology



■ Special Trained Personnel

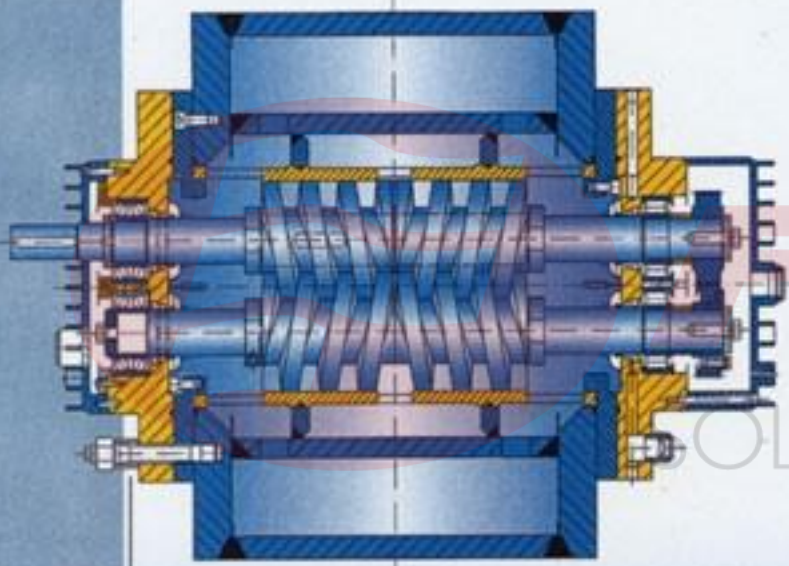

Single-acting mechanical seals with non-pressurized buffer system.

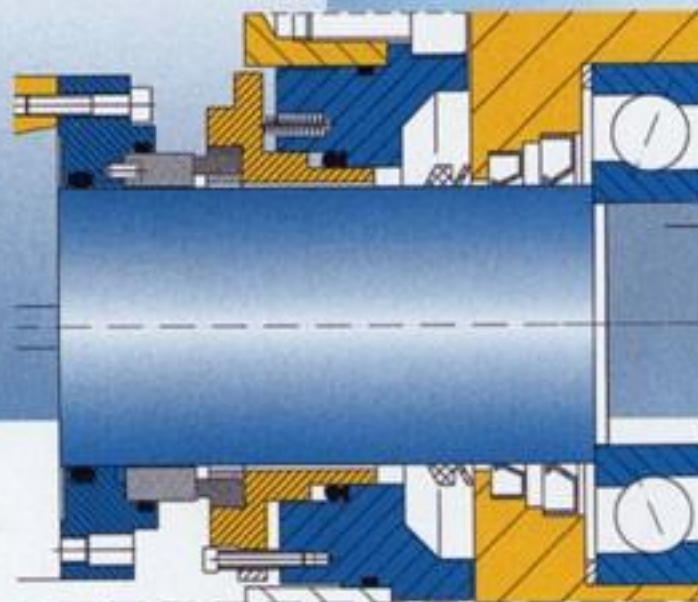

Inlet and discharge flanges located on upper side provide enhanced dry running capability.

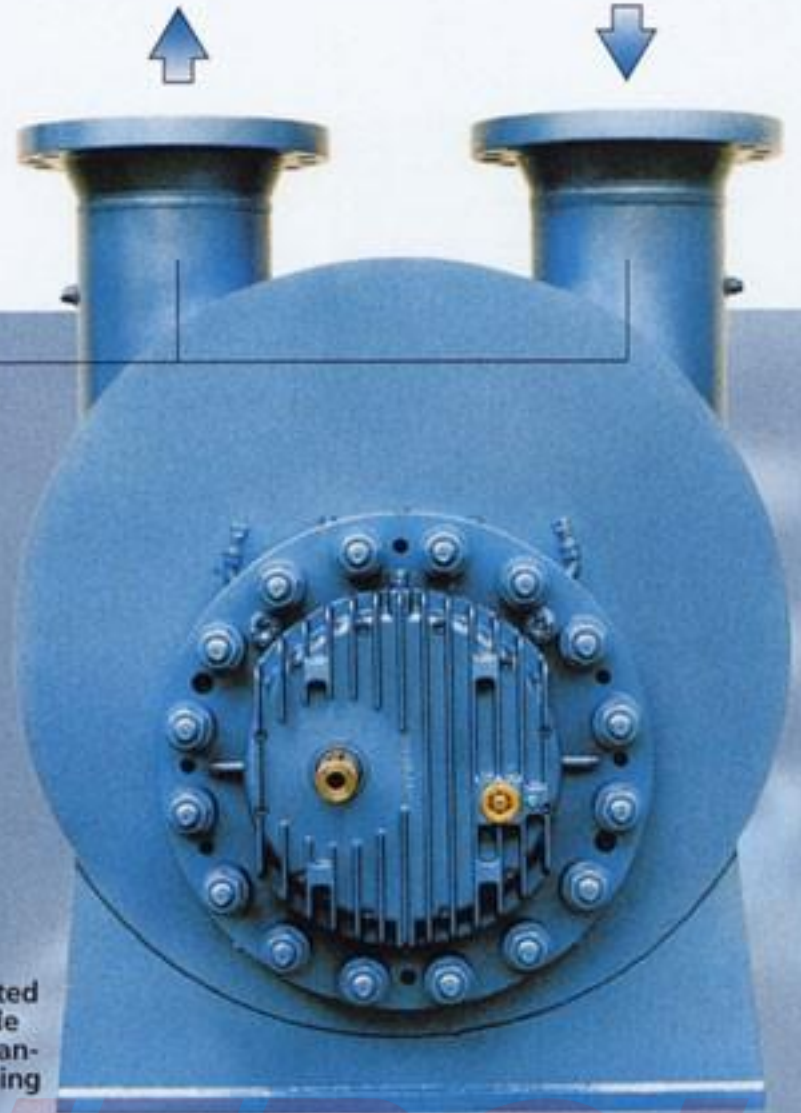

Special pump design allows use of simplified single-acting mechanical seals, i. e. no need for seal buffer system. With wear-resistant

silicon carbide/carbon sealfaces. The patented integrated separation system provides permanent flooding of mechanical seals.

### ■ MPC-Series Advantages

- Design for inlet pressures up to 1,000 psi (70 bar) and differential pressures up to 1,000 psi (70 bar).
- Capacity up to 300,000 BPD (2,000 m<sup>3</sup>/h).
- 100 % dry running capability.
- Oil-lubricated external bearings.
- Patented integral circulation system.

# Diff. press. up to 1,000 psi (70 bar)

**Bornemann  
Multiphase Pumps**  
MPC Series Technology –  
Specific To Your Needs

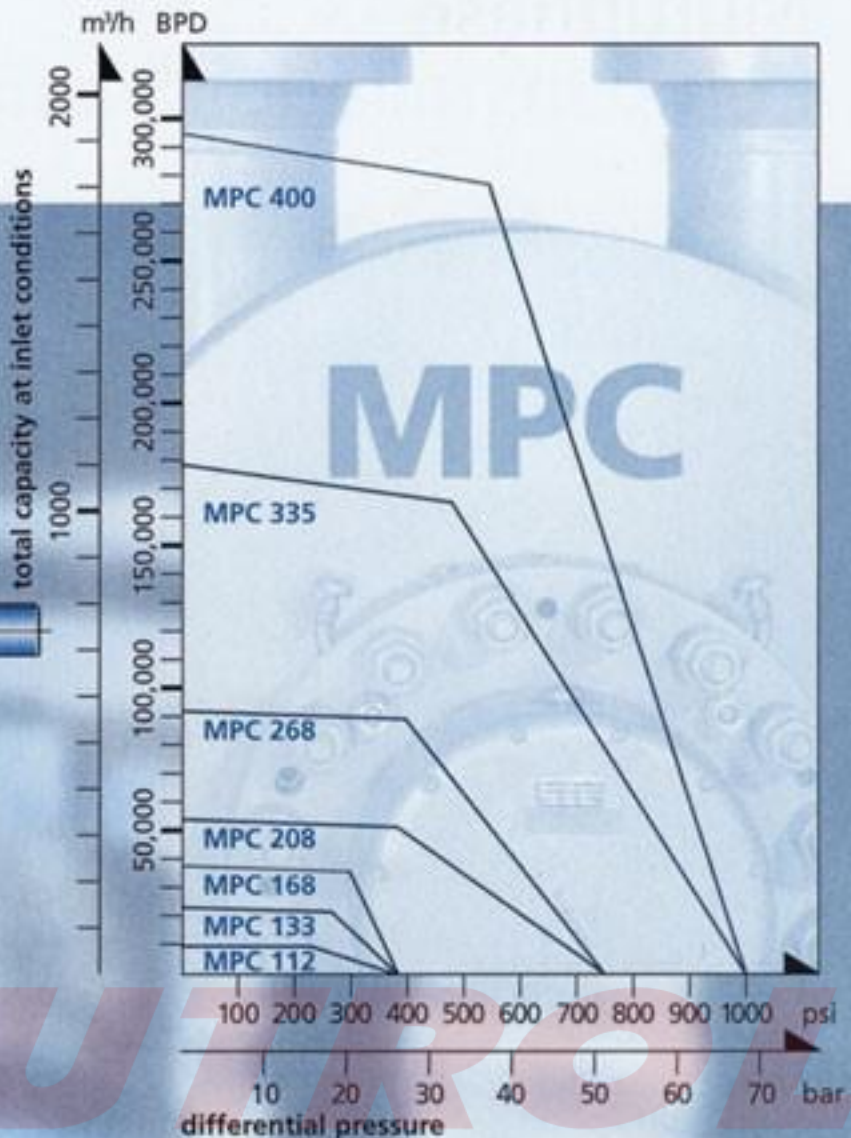
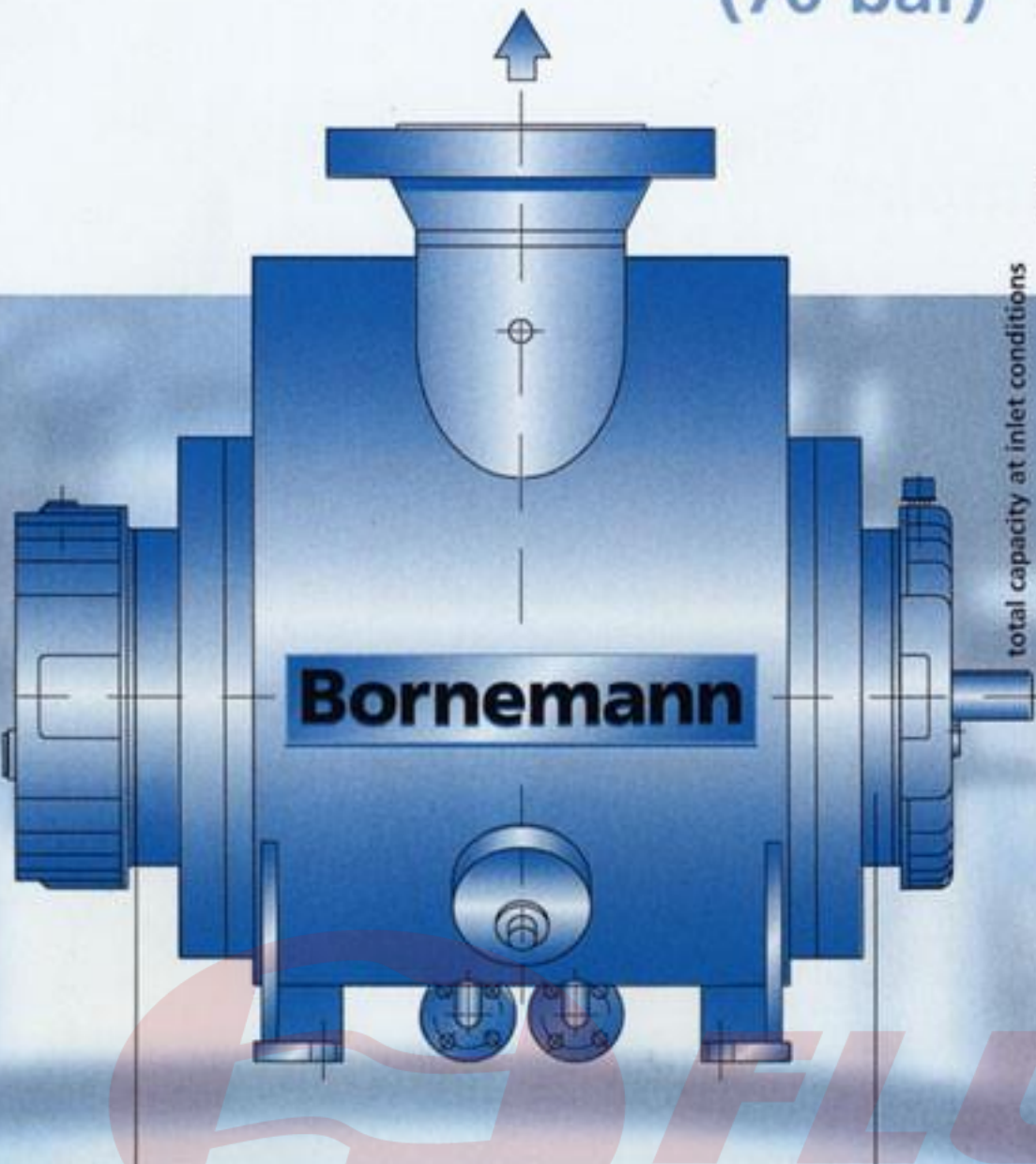

Oil-lubricated external bearings and timing gears ensure maximum service life and minimum maintenance requirements even in heavy duty applications.

SOLUÇÃO EM ALTA PRESSÃO!

**■ Bornemann Expert Assistance**  
Our Applications Engineering Department and Technical Sales Consultants will provide you professional support in selecting the Bornemann multiphase pump which best fits your needs.

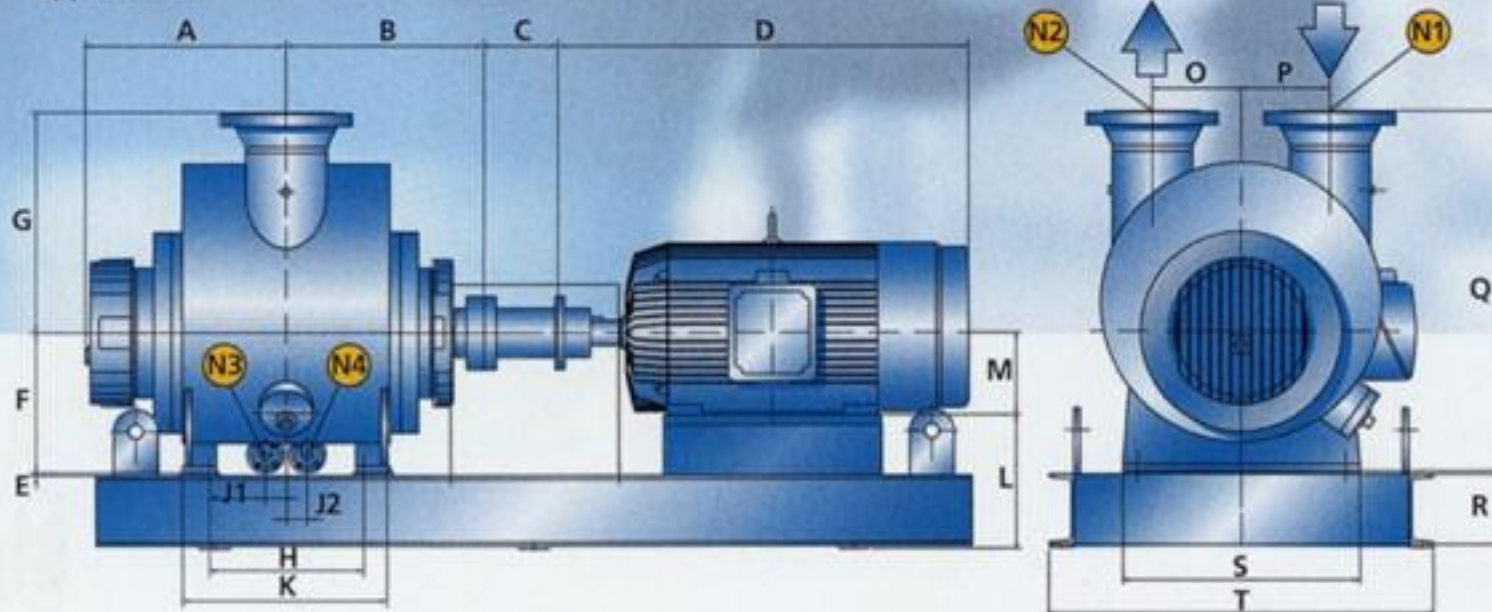

→→→ Please take a look at the jacket flap of this brochure for further information concerning data.

Get In Contact: Phone +49 (0) 5724 390-0 ■ Fax +49 (0) 5724 390-290  
E-mail: info@bornemann.com ■ Internet: www.bornemann.com

## Multiphase Pump Installation Examples



### ■ Bornemann Multiphase Pumps – Where Are They Used?

#### ■ Declining Fields

To upgrade low pressure streams to nominal system pressure.

#### ■ Marginal Fields

To allow profitable exploitation of small fields by connecting them to larger fields.

#### ■ Offshore Fields

To transport production from satellite platforms to the host platform and onward to onshore facilities. Separator stations or other flow conditioning systems are not required, providing significant space and weight savings.

#### ■ Pipeline Transfer

To convey production from large fields to central processing facilities without need for separation.

#### ■ Winter Service In Cold Areas

To reduce wellhead pressure, thereby avoiding clogging of flow lines due to hydrate formation.

Bornemann – well known for quick and perfect support even on-site.



**CONTROL**  
SOLUÇÃO EM ALTA PRESSÃO!





■ Offshore installation in the Gulf of Mexico for production boosting of declining wells.

■ MPC 208-38

- Fluid Stream: 1,207 BFPD (8 m<sup>3</sup>/h)
- Gas Stream: 370 MSCFD (436 sm<sup>3</sup>/h)
- Gas Content: 95 %
- Inlet Pressure: 30 psi (2 bar)
- Discharge Pressure: 682 psi (47 bar)
- Pump Capacity: 23,400 BPD (155 m<sup>3</sup>/h)
- Shaft Power: 322 HP (240 kW)



■ Offshore installation in the Caribbean sea: provides increased production by reducing well head pressure.

■ MPC 208-67

- Fluid Stream: 4,650 BFPD (31 m<sup>3</sup>/h)
- Gas Stream: 4,600 MSCFD (5,433 sm<sup>3</sup>/h)
- Gas Content: 78 %
- Inlet Pressure: 710 psi (49 bar)
- Discharge Pressure: 1,000 psi (69 bar)
- Pump Capacity: 21,100 BPD (140 m<sup>3</sup>/h)
- Shaft Power: 158 HP (118 kW)

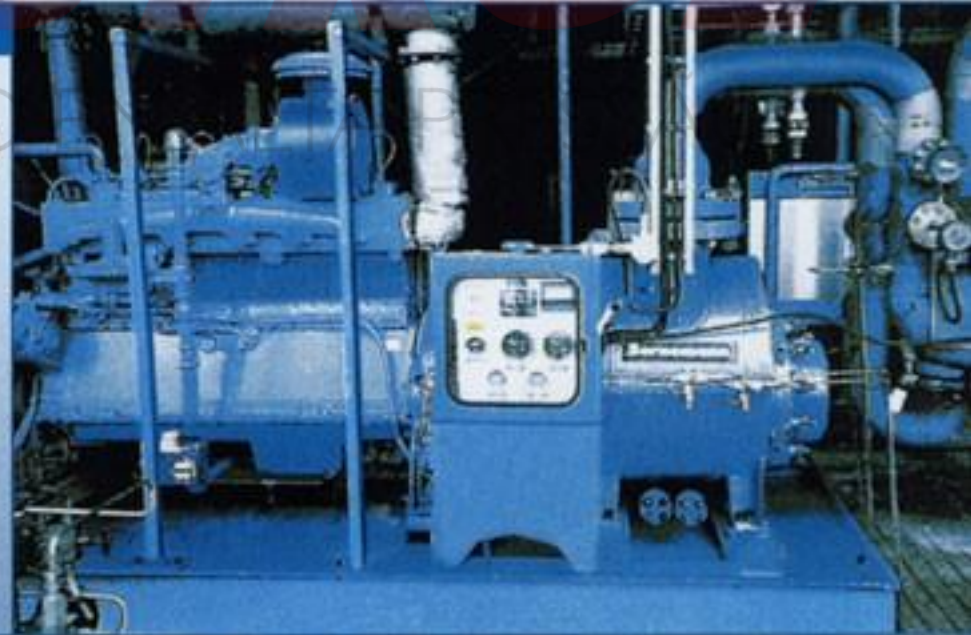

# Bornemann Multiphase System Solutions In Perfection



EXTRA  
SOLUTIONS BY A PRESS ©



## Multiphase – Introduction Of The Standard System Technology

### ■ Experience Is The Key

- As shown by decades of experience, correct selection of components is the key to successful operation of a pump system as a whole.
- Bornemann has the know-how and expertise required for the design of flange-to-flange solutions tailor-made for your specific application.
- Planning, design, manufacturing, installation and service – Bornemann provides it all – along with single-source responsibility.

Driver/Possibility for drivers:  
■ E-motor, fix speed  
■ E-motor, variable speed  
■ Diesel engine  
■ Gas engine

Pump  
■ MW  
■ MPC

Junction box  
on skid for connection  
to control cabinet.

Baseplate

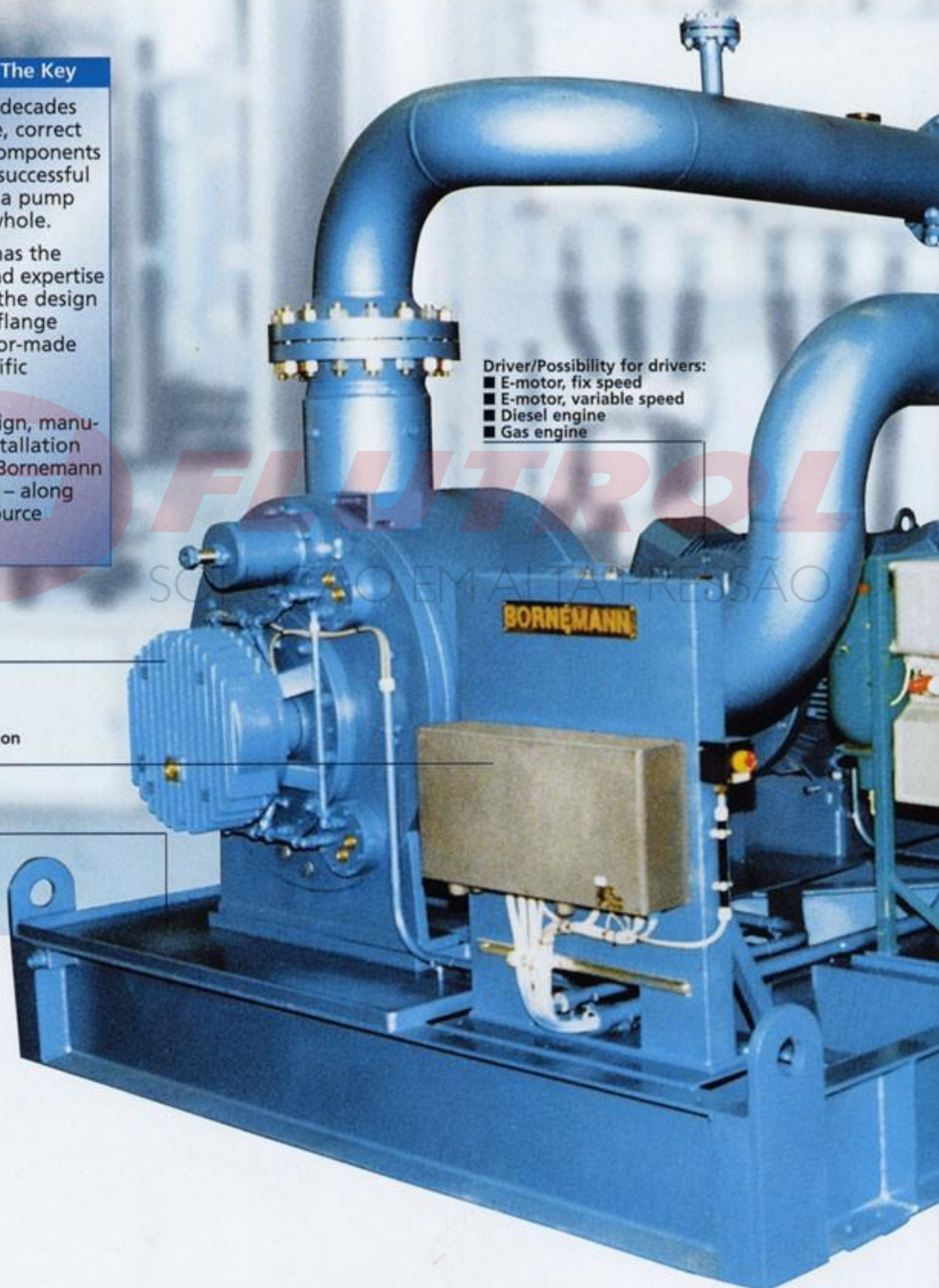

**FLUTROL**  
SOLUÇÃO EM ALTA PRESSÃO

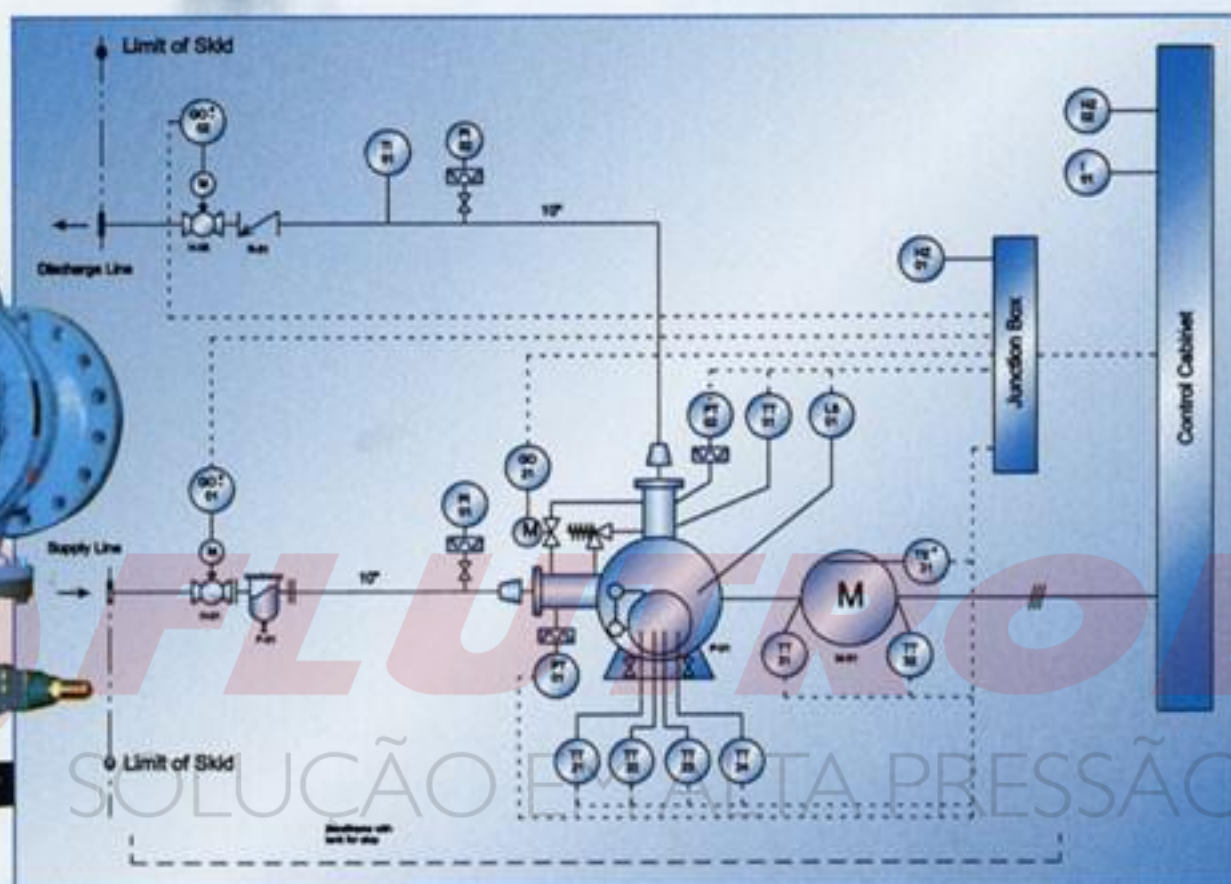
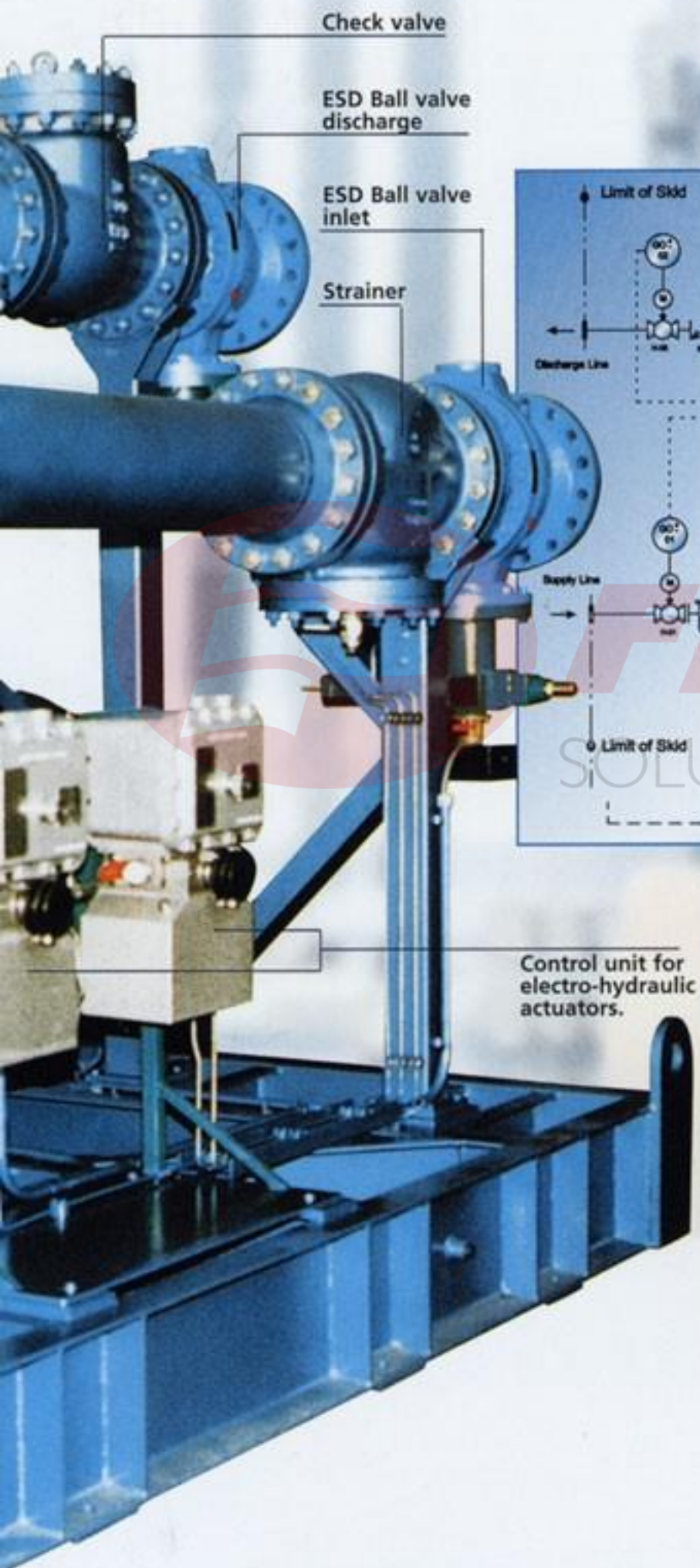

**Economic Advantages**

- Increased production output by up to several 100 %.
- Rapid return of investment, often within a few weeks.
- Reduced capital investment, as field separator stations are not required.

## Multiphase System Configuration

### System

■ Bornemann Multiphase Systems typically incorporate the following:

- One pump skid with inlet & discharge piping
- Piping auxiliaries such as check valves, gate valves, safety valves, and strainers
- Variable frequency control inverter drive
- Instrumentation, controls, and monitoring system

Completely automated Multiphase Systems are now available from Bornemann; subsequently, the equipment is extremely simple to run and requires little if any action by the operators.

### Layout

■ The basic layout of a Bornemann Multiphase System is comprised as follows:

#### Skid:

- Multiphase Pump
- Electric motor or gas/diesel engine
- Coupling
- Baseplate
- Inlet & discharge piping to edge of skid

#### Control & Monitoring System:

- PLC controlled actions of the system sequences safety shutdown relay chain independent of the PLC
- One button start/stop
- Optional vibration monitoring of pump bearings
- Optional fire and gas detection/Alarm system

#### Inlet Side:

- Inlet ESD valve (fail safe close)
- Simplex or duplex strainer

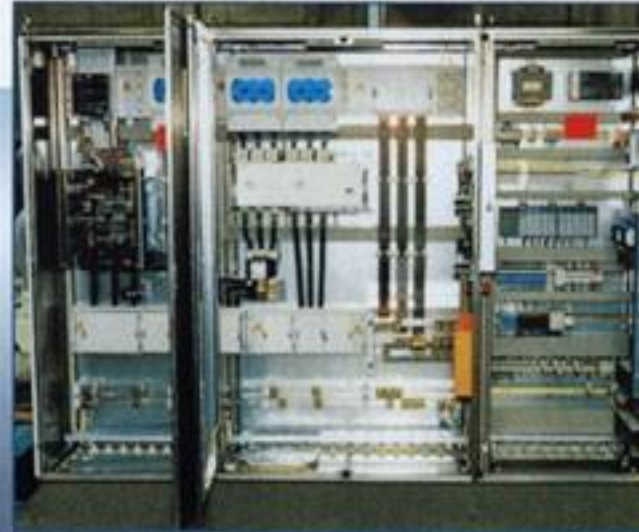

#### Discharge Side:

- Check valve (common or nozzle type)
- Discharge ESD valve (fail safe close)
- Safety relief valve
- Depressurizing valve

#### Other Available Features:

- Bypass line between inlet and discharge line for natural flow
- Automatic or manually controlled sump pump to evacuate drain tank integrated into the baseplate
- Remote control operation via modem to a master control room

#### Instrumentation:

Various gauges, switches and transmitters can be incorporated to monitor system parameters such as pressure, temperature, and vibration depending on the clients' needs.



## Testing

- All Bornemann Multiphase Systems are tested at the factory to assure that all components interface properly and function according to the design. Additionally, Bornemann can provide factory training to the clients' personnel as well as on-site assistance for start-up and commissioning or routine maintenance by our qualified field service engineers anywhere in the world.

## Safety

- The primary design philosophy behind each and every Bornemann Multiphase System is safety for both the overall system and the environment.

## Conclusions

- In summary, the advantages Bornemann Multiphase Systems provide are:

- Safe & reliable system philosophy
- Single source supply & responsibility
- Transfer of field experience with over 100 installations worldwide
- Engineered system designed specifically for your field conditions
- Factory tested system saving both time and money at the installation
- Training by experienced factory personnel



## Multiphase System Installation Examples



### ■ Bornemann Multiphase Pumps – Selection Of Our Customers Worldwide

- Amoco Texas, USA
- Caltex Pacific, Indonesia
- Corpoven San Tomé, Venezuela
- Lagoven, Morichal, Venezuela
- LUKoil Kogalym, Russia
- LUKoil Langepas, Russia
- Mobil Lastrup, Germany
- Mobil Oil Gas Plant, Canada
- Perez Companc, Venezuela
- Petro Canada, National Oilwell, Canada
- Preussag Energie, Germany
- Shell House Mountain, Canada
- Tatoi, Tartastan, Russia

Electrification,  
hard- and soft-  
ware – our  
single-source  
competence  
in all fields  
guarantees  
you perfect  
support.

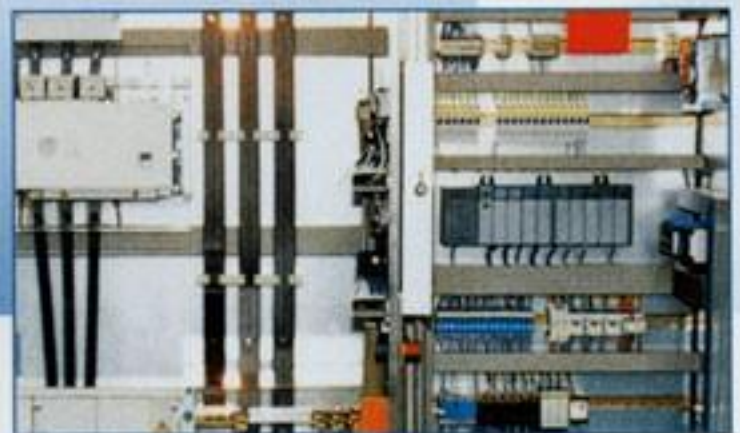





■ Onshore installation on an existing flow station.

■ MW 9.5zk-53

- Fluid Stream: 2,726 BFPD (18 m<sup>3</sup>/h)
- Gas Stream: 1,514 MSCFD (1,787 sm<sup>3</sup>/h)
- Gas Content: 97 %
- Inlet Pressure: 305 psi (2,1 barg)
- Discharge Pressure: 580 psi (40 barg)
- Pump Capacity: 91,000 BPD (602 m<sup>3</sup>/h)
- Shaft Power: 977 HP (729 kW)



■ World-wide first field development using multiphase technology.

■ MW 9.5zk-90

- Fluid Stream: 11,798 BFPD (78 m<sup>3</sup>/h)
- Gas Stream: 1,278 MSCFD (1,500 sm<sup>3</sup>/h)
- Gas Content: 92 %
- Inlet Pressure: 10,1 psi (0,7 barg)
- Discharge Pressure: 261 psi (18 barg)
- Pump Capacity: 147,000 BPD (977 m<sup>3</sup>/h)
- Shaft Power: 1,114 HP (831 kW)



## Worldwide Services – Complete Program For Our Customers

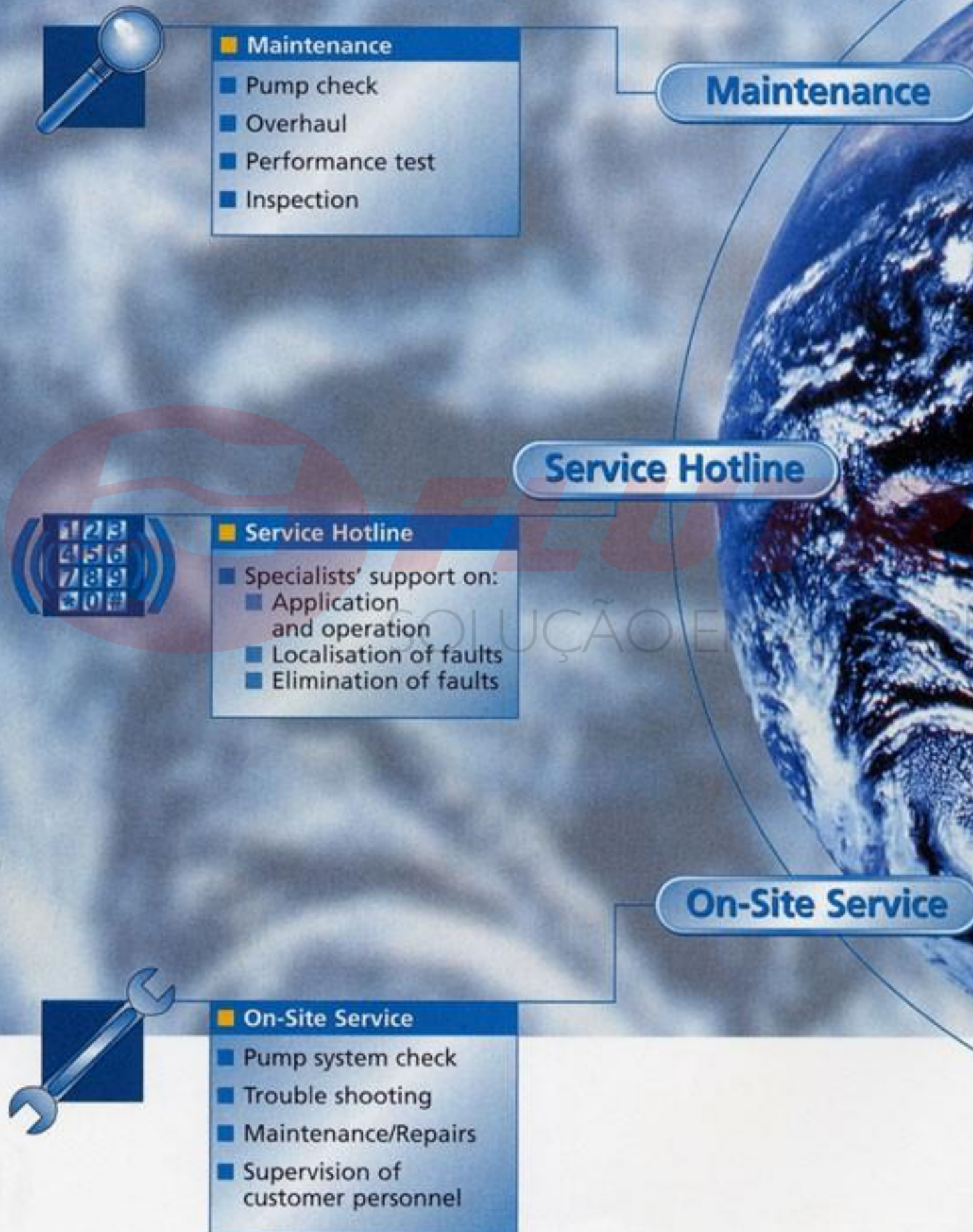



## Parts Logistics

### ■ Parts Logistics

- Proposal for a system-adapted spare parts-components-storage:
  - at the location
  - in the regional service workshops

## Training

### ■ Training

- Transfer of service know-how
- Seminars at the Bornemann facility and on-site
- Training on the job

## Support

### ■ Support

- On-site testing of system after commissioning
- Quick and direct support on changes in hard- and software

**MW-Series**

	MW 5.2zk	MW 6.5zk	MW 7.3zk	MW 7T.3zk	MW 8.5zk	MW 9.5zk
<b>Dimension [mm]</b>						
A	380	438	547	677	680	914
B	367	445	550	670	670	880
C	150	150	200	250	250	300
D	766	843	1,004	1,700	1,850	2,240
E	40	40	40	40	40	40
F	315	335	400	475	560	750
G	55	75	100	125	150	200
H	425	500	550	625	850	850
K	220	280	380	520	490	560
L	330	440	540	700	680	780
M	355	350	360	410	400	630
N	200	225	280	355	450	560
O	420	500	550	700	800	1,050
P	425	500	550	625	850	850
Q	370	410	500	600	710	950
R	200	200	200	250	250	400
S	290	330	390	600	650	1,100
T	900	900	1,000	1,200	1,400	1,600
<b>Weights [kg]</b>						
Pump	350	500	900	1,400	2,500	5,600
Baseplate	250	400	800	900	1,100	3,000
Motor	254	335	575	1,700	2,700	5,400
Total	854	1,235	2,275	4,000	6,300	14,000
<b>Flanges/Connections</b>						
N1	4" ANSI 300 lbs	6" ANSI 300 lbs	8" ANSI 300 lbs	10" ANSI 300 lbs	12" ANSI 300 lbs	16" ANSI 300 lbs
N2	4" ANSI 300 lbs	6" ANSI 300 lbs	8" ANSI 300 lbs	10" ANSI 300 lbs	12" ANSI 300 lbs	16" ANSI 300 lbs
N3	1/2" NPT	1/2" NPT	1/2" NPT	1" NPT	1" NPT	2" NPT
N4	1/2" NPT	1/2" NPT	1/2" NPT	1" NPT	1" NPT	2" NPT

All dimensions are preliminary and can be changed without notice.

**MPC-Series**

	MPC 112/133	MPC 133	MPC 166	MPC 208	MPC 268	MPC 335
<b>Dimension [mm]</b>						
A	438	438	511	643	637	810
B	445	445	550	670	670	880
C	150	150	150	200	200	300
D	766	930	1,200	1,720	1,960	2,390
E	40	40	40	40	40	40
F	315	355	400	475	560	750
G	685	575	650	750	1,000	1,170
H	280	280	380	520	500	600
K	440	440	540	700	680	780
J1	50	50	50	70	75	80
J2	50	50	50	70	75	80
L	355	325	375	365	400	630
M	200	250	315	400	450	560
O	175	200	250	300	375	450
P	175	200	250	300	375	450
Q	1,000	1,000	1,050	1,225	1,560	1,920
R	200	200	250	250	250	400
S	500	500	700	800	1,100	1,200
T	1,000	1,000	1,100	1,300	1,600	1,800
<b>Weights [kg]</b>						
Pump	800	900	1,300	2,700	3,440	5,600
Baseplate	300	400	900	1,100	1,200	3,000
Motor	254	425	795	2,000	3,300	6,300
Total	1,354	1,725	2,995	5,800	7,940	14,900
<b>Flanges/Connections</b>						
N1	4" ANSI 300 lbs	6" ANSI 300 lbs	8" ANSI 300 lbs	10" ANSI 300 lbs	12" ANSI 300 lbs	16" ANSI 600 lbs
N2	4" ANSI 300 lbs	6" ANSI 300 lbs	8" ANSI 300 lbs	10" ANSI 300 lbs	12" ANSI 300 lbs	16" ANSI 600 lbs
N3	1/2" NPT	1/2" NPT	1" ANSI 300 lbs	1" ANSI 300 lbs	1" ANSI 300 lbs	2" ANSI 600 lbs
N4	1/2" NPT	1/2" NPT	1" ANSI 300 lbs	1" ANSI 300 lbs	1" ANSI 300 lbs	2" ANSI 600 lbs

All dimensions are preliminary and can be changed without notice.

**Visions  
Become Reality**

**With Subsea Multiphase Boosting  
Into The Next Millennium**

**■ Subsea Multiphase Boosting**

- 2,000 m water depth
- Up to 2,500 kW power consumption
- At 24,000 h service intervals
- Come and visit our prototype!



**New Type MPC:  
Bigger – Better – Bornemann**

We Match With The Customers Requirements

**■ MPC 500**

- Max. capacity:  
600,000 bpd (4,000 m<sup>3</sup>/h)
- Max. absorbed power:  
6,800 HP (5,000 kW)
- Differential pressure  
up to 1,450 psi (100 bar)



Pumps and Systems for Industry,  
Environmental and Shipbuilding

[www.bornemann.com](http://www.bornemann.com)

Joh. Heinr. Bornemann GmbH  
Postfach 1162  
31676 Obernkirchen  
Germany  
Fon +49 5724 390-0  
Fax +49 5724 390290  
[info@bornemann.com](mailto:info@bornemann.com)



# FLUTROL

Good communication with our customers is an important feature in Bornemann's Quality Program, from initial project consultation to maintenance. Professional support and fast service are top priorities. Specialists in pumps and systems located in our company headquarters and in nearly 100 representatives

and agencies through the world provide professional quality support on a local level. Our employees and representatives are trained at our training center in order to stay current on new technologies and provide the best support available to our customers.

0.035.2100, rev. 5, 12/06

Printed in Germany

**USA:**  
**Bornemann Pumps Inc.**  
P.O. Box 1769  
Matthews, NC 28106  
USA  
  
Fon:  
+1 704 8498636  
Fax:  
+1 704 8498637  
[info.usa@bornemann.com](mailto:info.usa@bornemann.com)

**Canada:**  
**Bornemann Inc. Canada**  
320 441, 5<sup>th</sup> Avenue, S. W.  
Calgary, Alberta  
Canada T2P 2V1  
  
Fon:  
+1 403 6680552  
Fax:  
+1 403 2624073  
[info.cdn@bornemann.com](mailto:info.cdn@bornemann.com)

**Argentina:**  
**Bombas Bornemann S.R.L.**  
Armenia 2898  
B1605CDP Munro  
Prov. Buenos Aires  
Argentina  
  
Fon:  
+54 11 47568008  
Fax:  
+54 11 47565541  
[info.ar@bornemann.com](mailto:info.ar@bornemann.com)  
[www.bornemann-ar.com](http://www.bornemann-ar.com)

**China:**  
**Bornemann Pumps & Systems (Tianjin) Co., Ltd.**  
Jinbin General Building No. 6,  
No. 45 Muning Road  
TEDA, Tianjin  
P. R. China 300457  
  
Fon:  
+86 22 66297800  
Fax:  
+86 22 25326799  
[info.cn@bornemann.com](mailto:info.cn@bornemann.com)  
[www.bornemann-cn.com](http://www.bornemann-cn.com)

**Singapore:**  
**Bornemann Pumps Asia Pte. Ltd.**  
25 Intern. Business Park  
German Centre, # 04-08  
Singapore 609916  
Singapore  
  
Fon:  
+65 6 5616782  
Fax:  
+65 6 5616784  
[info.sg@bornemann.com](mailto:info.sg@bornemann.com)